

## CBD20J-H Electric Pallet Truck

### Characteristics:

1. The truck has compact structure and small turning radius, suitable for narrow space;
2. Electric lifting limit function: when the fork rises to the top, the system will automatically cut the lifting circuit, with high safety, low energy consumption and long service life;
3. Adopt is simple, economic and high reliable; mechanical steering
4. Emergency stop switch and emergency reverse device as standard configuration. ensure truck safety;
5. Auxiliary wheels on both sides to improve driving stability;
6. AC drive system has light operation and excellent performance;
7. Long operating handle is ergonomic and comfortable for operation.



## CBD20J-H

### Manufacturer's Data and Design Characteristics

Characteristics		
1.1	Manufacturer	HELI
1.2	Model	CBD20J-H
1.3	Operator type	步行式 Pedestrian propelled
1.4	Rated capacity	Q (kg) 2000
1.5	Lift height	h3 (mm) 200
1.6	Service weight with battery	kg 520
1.7	Load centre	c (mm) 600
1.8	Axle centre to fork face	x (mm) 962
1.9	Wheel base	y (mm) 1388
1.10	Controller	CURTIS
Wheels		
2.1	Wheels type	Polyurethane
2.2	Driving wheel size	Φ×w(mm) Φ230×70
2.3	Bearing wheel size	Φ×w(mm) Φ80×70
2.4	Additional wheels(dimensions)	Φ×w(mm) Φ100×40
2.5	wheels, number front/rear (x= driven)	1x+2/4
2.6	track width, rear, loading side	b11 (mm) 390/525
Dimensions		
3.1	Overall length	l1 (mm) 1742
3.2	Length to fork face	l2 (mm) 592
3.3	Overall width	b1 (mm) 700
3.4	Fork dimensions	s/e/l (mm) 50/160/1150
3.5	Width of forks	b5 (mm) 550/685
3.6	Lowered height	h13 (mm) 85
3.7	Min. Ground clearance	m2 (mm) 35
3.8	Height drawbar in driving position min./max.	h14 (mm) 825/1278
3.9	Aisle width with pallet 1000 x 1200 across forks	Ast (mm) 1962
3.10	Aisle width with pallet 800 x 1200 along forks	Ast (mm) 2012
3.11	Min. Turning radius	Wa (mm) 1517
Performance		
4.1	Travel speed, with/without load	(km/h) 4.2/4.5
4.2	Lifting speed, with/without load	(mm/s) 21/27
4.3	Lowering speed, with/without load	(mm/s) 38/38
4.4	Max. Gradeability laden/unladen	(%) 8/15
4.5	Service brake type	Electromagnetic brake
Drive and Battery		
5.1	Drive motor, output s2 60 min.	(kW) 1.3 (AC)
5.2	Lift motor rating at s3 15%	(kW) 0.8 (DC)
5.3	Battery according to din 43531/35/36 a,b,c,no	no
5.4	Battery voltage/rated capacity	(V/Ah) 24/210
5.5	Battery weight (± 5%)	(kg) 195
Others		
6.1	Type of drive control	AC
6.2	Sound pressure level at driver's ear	(dB(A)) ≤70
6.3	Steering type	Mechanical steering

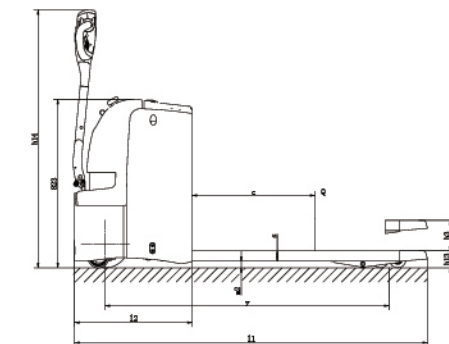
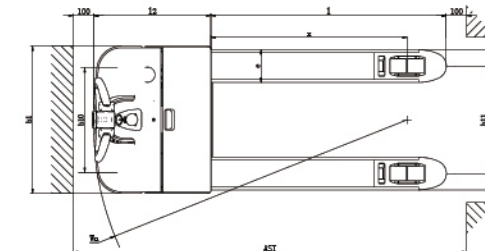

**ANHUI HELI CO., LTD.**

Add / No.668, FangXing Road, Hefei, China  
Fax / +86-551-63639966

Tel / +86-551-63639068(America); 63639258(Europe);  
63639358(Asia); 63662105(Africa & Middle East);  
63639530(Key Accounts Division); 63662105(Wheel loader)